

~~RESERVE COPY~~
PATENT SPECIFICATION

599,793



Application Date: March 7, 1944. No. 4257/44.
Complete Specification Left: June 19, 1944.
Complete Specification Accepted: March 22, 1948.

PROVISIONAL SPECIFICATION

Improvements in or relating to Walls, Roofs, Floors, and Ceilings

We, HENRY WYNMALEN, a subject of the Queen of the Netherlands, and JOHN WELLINGS POWELL, a subject of the King of Great Britain, both of Hare Hatch Estate Office, Twyford, Berkshire, do hereby declare the nature of this invention to be as follows:—

This invention relates to walls, roofs, floors, and ceilings, its chief object being to provide pre-fabricated panel units which can be built up into a building, or form the external walls of a building, without the employment of visible fastening devices exposed to the weather. Another object is to enable cavity walls, roofs, floors, and ceilings to be constructed of similar pre-fabricated units, while minimising the employment of skilled labour.

The said unit panel may be made of metals, metal alloys, pressed or cast or wrought, protected metal, asbestos cement, or combinations of metals and cement products, including such as concrete and reinforced concrete, and combinations of metals and woods, plywoods, insulation boards or slabs, plaster boards and like building materials commonly used for cladding or lining buildings.

According to the invention each unit panel is provided at its upper and lower ends, and in some cases at one or both sides also, with clips adapted to interlock with adjacent units, and with channel shaped joists, purlins, or other structural members.

The clip at the upper or leading end of a panel may be a hook or hook-shaped rib extending above the main body of the panel, while the clip at the lower or following end may be a hook or hook-shaped

rib the main portion of which is reverted or bent into a position parallel with the general plane of the panel, then turned over to form the hook. At one side of the panel there may be a hook or hook-shaped rib starting in the general plane of the panel, and at the other side a bevelled projection turned at a right angle to the said general plane. These clips besides engaging adjoining units are adapted to engage channel shaped joists and purlins in the structure of the building, and units of similar shape can be used for both upper and lower, or inner and outer surfaces.

At the apex of the roof, inner and outer caps are similarly provided with clips of hook shape in cross section to engage the clips at the tops of the adjacent inclined roof sheets. At the eaves, suitably curved members are provided with clips to engage the tops of the wall units and the bottoms of the lower roof units.

The shapes of the clips at the upper and lower floors may be modified as required.

Wall cladding or lining embodying this invention can be very quickly assembled when the lower units have been placed in position, and can be quickly dismantled by removing first the highest units and then the lower units.

Dated this 7th day of March, 1944.
HASELTINE, LAKE & CO.,
28, Southampton Buildings,
London, England,
and
19—25, West 44th Street, New York,
U.S.A.,
Agents for the Applicants.

COMPLETE SPECIFICATION

Improvements in or relating to Walls, Roofs, Floors, and Ceilings

We, HENRY WYNMALEN, a subject of the Queen of the Netherlands, and JOHN WELLINGS POWELL, a subject of the King of Great Britain, both of Hare Hatch Estate Office, Twyford, Berkshire, do hereby declare the nature of this inven-

tion and in what manner the same is to be performed, to be particularly described and ascertained in and by the following statement:—

This invention relates to walls, roofs, floors and ceilings, its chief object being

1/1

to provide pre-fabricated panel units which can be built up into a building, or form the walls or roofing of a building, without the employment of visible fastening devices, which in the case of external walls or roofing, would be exposed to the weather. Another object is to enable cavity walls, roofs, floors, and ceilings to be constructed of similar pre-fabricated units, while minimising the employment of skilled labour. Another object is to provide a vertical side joint between the panels which shall be weather-tight and act as an expansion joint, so remaining an efficient joint indefinitely, being thus distinguished from the usual form of joint now used between pre-fabricated panel units where some form of mastic is used to make the joint, which in the course of time after a number of cycles of expansion and contraction ceases to be efficient.

The said unit panel may be made of metals, metal alloys, pressed or cast or wrought, protected metal, asbestos-cement, or of wood, plywood, plastics, or laminated plastic products, or combinations of metals and cement products, including such as concrete and reinforced concrete, and combinations of metal and woods, plywoods, insulation boards or slabs, plaster boards, plastics or laminated plastics, and like building materials which may be used for cladding or lining buildings.

According to the invention each unit panel is provided at its upper or leading end and at its lower or following end with integral or permanently attached clips or flanged members adapted by rectilinear movement of the panel in its own plane and perpendicular to the end carrying the clips or flanged members to be interengaged tightly with adjacent units, or with the clips or members of adjacent units, and with the flanges of joists, purlins, or of other structural members.

The clip at the upper or leading end of a panel may be a resilient hook or hook-shaped rib extending along or near the upper edge of the panel, to grip a supporting rail or member, while the clip at the lower or following end may be a hook or hook-shaped rib the main portion of which is reverted or bent into a position parallel with the general plane of the panel, then turned over to form the hook, which is sprung over the top hook of a lower panel. At one side of the panel there may be a hook or hook-shaped rib starting in the general plane of the panel, and at the other side a bevelled projection turned at a right angle to the said general plane. These clips besides engaging adjoining units are adapted to engage joists and purlins in the structure of the build-

ing, and units of similar shape can be used for both upper and lower, or inner and outer surfaces. The clips may be of the same material as the panels or of other material, and if not formed integrally with the panel, may be attached thereto by welding or any other suitable means.

At the apex of the roof, inner and outer caps are similarly provided with clips of hook shape in cross section to engage the clips at the tops of the adjacent inclined roof sheets. At the eaves, suitably curved members are provided with clips to engage the tops of the wall units and the bottoms of the lower roof units.

The shapes of the clips at the upper and lower floors may be modified as required.

Wall cladding or lining embodying this invention can be very quickly assembled when the lower units have been placed in position, and can be quickly dismantled by removing first the highest units and then the lower units.

In order that the said invention may be clearly understood and readily carried into effect the same will now be further described with reference to exemplifications illustrated in the accompanying drawings, wherein:—

Figures 1, 2 and 3 are respectively a plan, sectional side view, and lower end view of a unit panel suitable for use in external roofing.

Figure 4 represents a portion of a roof constructed in accordance with the invention.

Figure 5 is a cross sectional view illustrating particularly the manner of using the unit panels for the construction of internal and external walling surfaces with cavities between them.

Figure 6 is a cross sectional view illustrating cavity walling and a cavity between a ceiling and an upper floor.

Figure 7 is a fragmentary view illustrating interlocking clips of slightly modified form.

Figure 8 represents a further modification, showing two clips engaging a joist or other constructional building member.

In the drawings, A in Figure 1 indicates a panel provided with an upper or leading clip *a*, a lower or following clip *b*, and on the external units a turned up lip *c* and a roll *d*.

As shown in Figure 4, the units are placed in position on roof structural members *e* such as purlins of channel form. Internal units B differing from the external units by the omission of the lip *c* and roll *d* may be used to form with the external units a cavity roof, and similar units B may be used for the upper and lower surfaces of a horizontal ceiling,

thus forming a cavity ceiling. The ridge cap *f* and closing element *g* at the apex of the lining are also provided with clips of the form already designated by the reference letter *b*. The joists *h* support the ceiling panel units and a closing element having at each end clips *b*.

In Figure 5 the clips *a* and *b* are supported on structural members *k*. Some of the units are modified in shape to adapt them to particular positions, the unit *l* being curved to serve as a transition from the internal wall face to the internal slope lining, *m* being an external eaves unit, *n* an external weathering apron, and *p* an internal skirting unit, the shapes of all these being modified as may be required.

In the arrangement represented in Figure 6, *o* indicates the top of a foundation or of a masonry, brick or concrete wall above which the described cladding is begun; *g* indicates cavities in the wall, *r* a cavity between a ceiling and an upper floor, *s* a lower floor, which may also be made a cavity by adding lower panels. The panels may be constituted of flat sheets *t* of wood, plywood, asbestos-cement, or various building boards or slabs of insulating material or plastic or laminated plastic to which the clips *a* and *b* are secured by any suitable means. The clips may be made in any suitable material such as wood, or in cast, extruded, drawn or pressed metal profiles, as for example *u* on the bottom edge and *v* at the top edge of an external unit of the wall, *w* at the bottom edge and *x* at the top edge of an internal unit. The floor unit panels *s* may be covered with attached floor surfacing *y*, such as linoleum, a composition material, plywood or boards, or other suitable floor covering material. The ceiling unit panels *z* may have attached surfacing *z'*, which may be plywood, plaster-board, fibre board, acoustic board, or other suitable material.

The side joints of these units may be formed in a variety of ways, first as already mentioned the roof cladding side joint may be effected by means of an up-standing lip *c* and companion roll *d*. Other methods are such as plain overlapping, joggle overlapping or halving lap after the fashion of interlocking tiles, any or all such methods being associated with the said clip forms *a* and *b*; or the side joint may follow the special form already described for the upper and lower clip form *a* and *b* respectively where *a* nests into *b* which embraces *o* and so forms an inter-engaging mutually supporting side joint, and may if desired be caused to engage with structural members at right

angles to the structural members already referred to such as *e*, *h*, *k*, and so become supported by the structural members on all four edges of the unit panels perimeter.

By the use of this invention, the piercing of holes in metal or other roofing, or walling sheets for the purpose of fixing bolts and nuts is eliminated, as is also the need for using bolts, screws, or nails for the purpose of fixing. Such piercing tends to cause deterioration of the sheets, and detracts from their weather-proof qualities.

Although the entire surface of the wall or roof is completely inter-engaged, one unit with all its neighbouring units, the processes of assembling and dismantling the units made according to the invention can be carried out with great rapidity.

Having now particularly described and ascertained the nature of our said invention and in what manner the same is to be performed, we declare that what we claim is:—

1. A unit panel for use in the construction of walls, roofs, floors, and ceilings, provided at its upper or leading end and at its lower or following end with integral or permanently attached clips or flanged members, adapted by rectilinear movement of the panel in its own plane and perpendicular to the end carrying the clips or flanged members, to be inter-engaged tightly with adjacent units or with the clips or flanged members of adjacent units, and with the flanges of joists, purlins, or of other structural members.

2. A unit as in Claim 1, which is also provided at one or both sides with members adapted to inter-engage with adjacent units.

3. Cavity floors and ceilings constructed of units as in Claim 1 or of units as in Claim 2, or of units as in Claim 1 and Claim 2 in combination.

4. Cavity walls and roofs constructed of internal panel units as in Claim 1 or Claim 2 and external panel units as in Claim 2.

5. Walls, roofs, floors, and ceilings constructed of panel units substantially as hereinbefore described with reference to the accompanying drawings.

Dated this 19th day of June, 1944.

HASELTINE, LAKE & CO.,

28, Southampton Buildings,

London, England,

and

19-25, West 44th Street, New York, 18,
U.S.A.,

Agents for the Applicants.

[This Drawing is a reproduction of the Original on a reduced scale.]

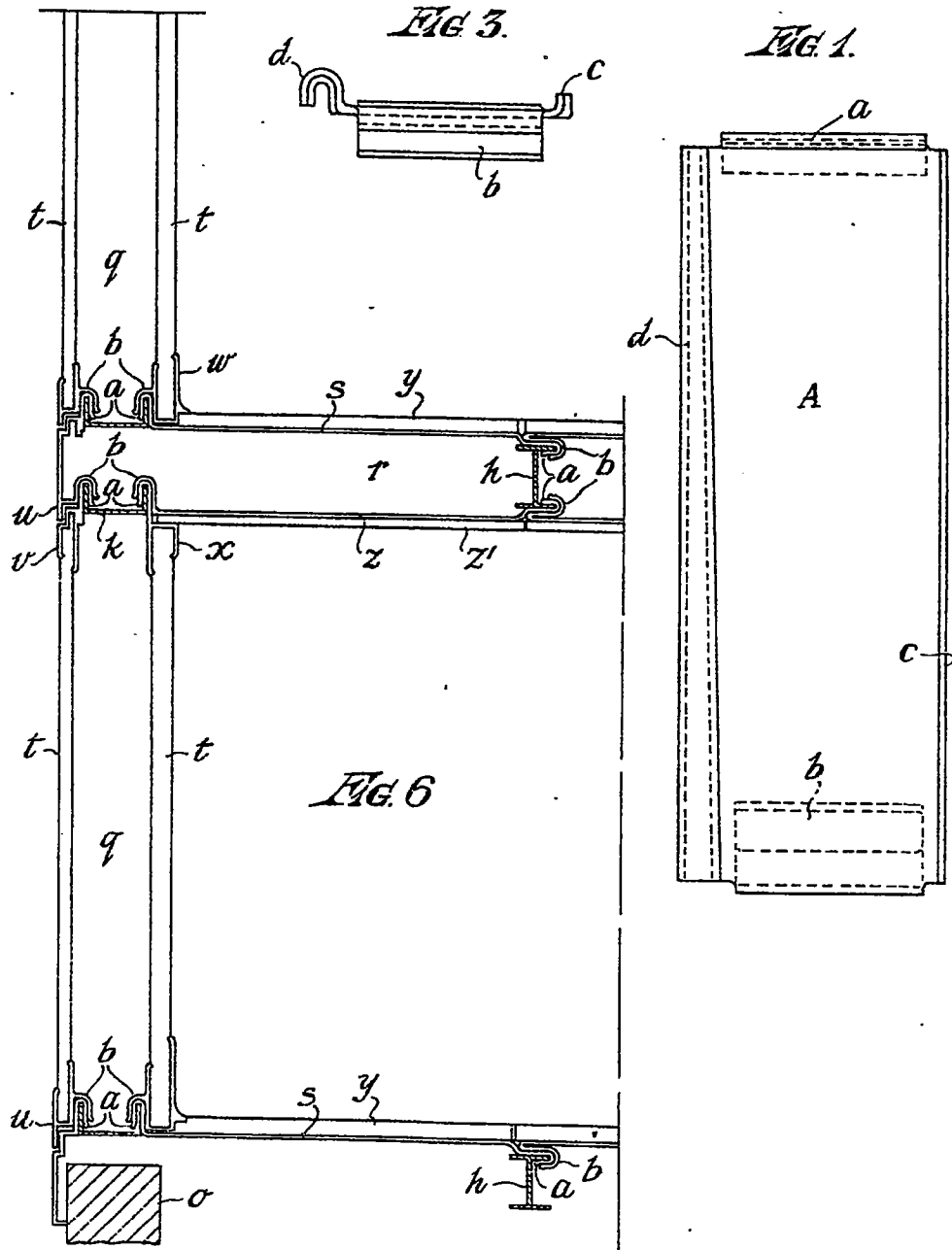

FIG. 1.

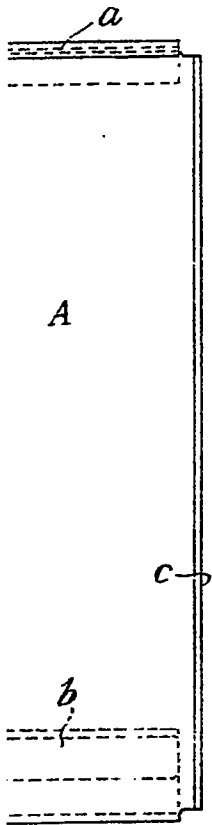

FIG. 7.

FIG. 2.

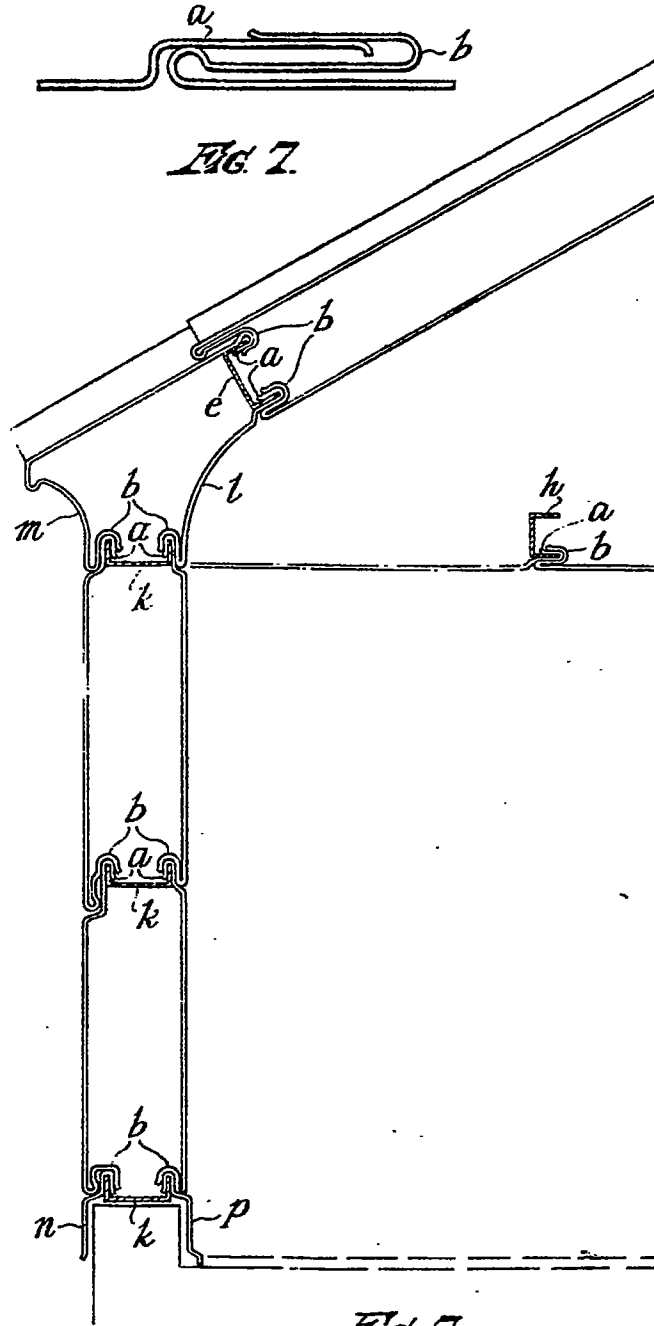
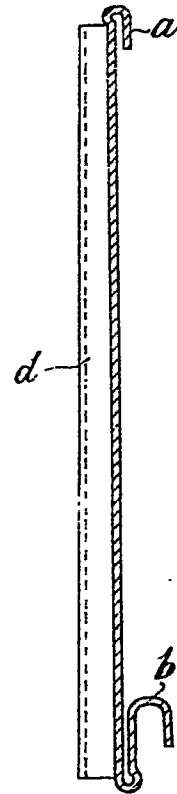
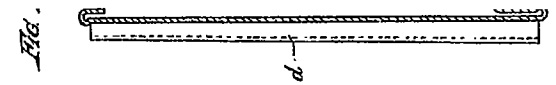
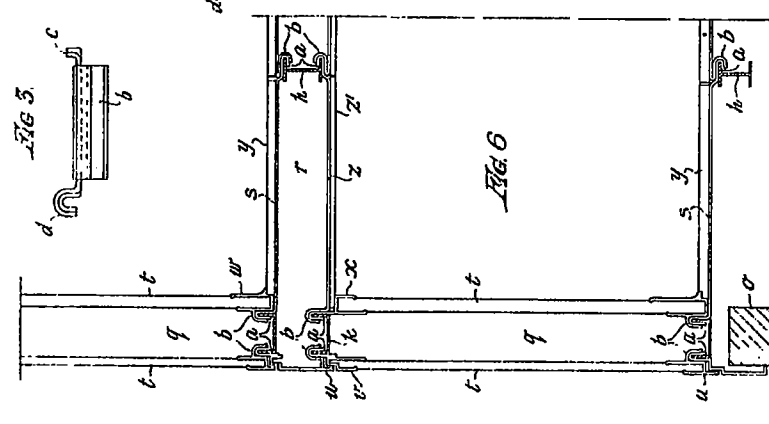
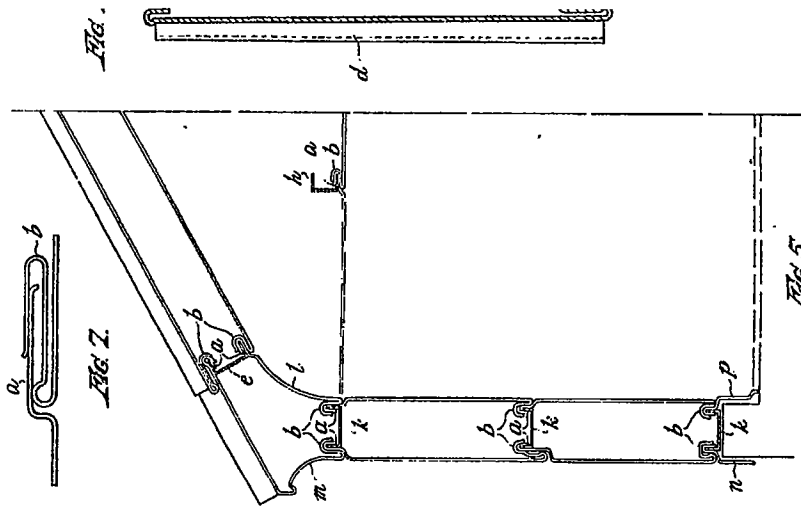

FIG. 5.



[This Drawing is a reproduction of the Original on a reduced scale.]

[This Drawing is a reproduction of the Original on a reduced scale.]

